

**Air Express**  
***C1000DF***



**CE**  
0086

***Service Manual***

## Table of Contents

Section	Description	Page
1.	Contraindications .....	1
2.	Receiving Inspection.....	1
3.	Repair Policy.....	2
4.	Specifications.....	2
5.	Control Panel Features.....	3
6.	Rear & Side Panel Features .....	4
7.	Cleaning.....	5
8.	Maintenance and Function Testing.....	5
9.	Function Test Check Sheet.....	9
10.	Calibration Procedure.....	10
11.	Troubleshooting.....	11
12.	Parts List .....	12
13.	Electrical Schematic.....	13
14.	Pneumatic Schematic.....	14

## Important

Before using the Air Express System, read and understand the Operator's Manual prior to each application.

Only qualified medical service personnel should repair the Air Express System.

In the event of any questions, contact your dealer for assistance.

## 1. Contraindications

Refer to Operator's Manual.

### Indications for Use / Theory of Operation

Refer to Operator's Manual.

### Safety Precautions

Review the following SAFETY PRECAUTIONS prior to servicing the Air Express system.

**⚠ DANGER**

- Risk of electric shock. Refer servicing to qualified service personnel, Explosion hazard. There is an explosion risk if this equipment is used in the presence of flammable anesthetics.

**⚠ WARNING**

- Never drop or insert any object into any opening of the control unit. Doing so may cause fire or electrical shock by shorting internal components.
- Do not spill food or liquids into the Control Unit. If spillage does occur, turn off the unit, disconnect it from its power supply and allow spill to completely dry.
- Keep unit away from radiators or other heat sources.

**⚠ CAUTION**

- Repairs should be performed only by qualified personnel familiar with repair practices for servicing medical devices. Do not attempt to repair the C1000DF Control Unit unless you possess these skills. Otherwise, damage to or malfunction of the control unit may result.

## 2. Receiving Inspection

Upon receipt, unpack the C1000DF Control Unit and inspect for concealed damage. Save all packing material. If any damage is found, notify the carrier at once and ask for a written inspection. Prepare a written description of any damage. Photograph any damage.

Failure to take the above action within 15 days of receipt may result in loss of claim.

**Do not return the Control Unit without first contacting your dealer**

### 3. Repair Policy

The control unit is warranted free of defects in material and workmanship for a period of two (2) years.

The control unit is warranted under the terms and conditions of the Gaymar Industries warranty in place at the time of purchase. A copy of the warranty is available upon request.

Control units may be returned to the factory for servicing (see Return Authorization).

For customers who choose to repair the control unit at their location, this manual contains information to allow a qualified technician to make necessary repairs.

#### 3.1 In-Warranty Repairs

All in-warranty repairs must be authorized by Gaymar's International or Technical Service departments before proceeding.

#### 3.2 Out-of-Warranty Repairs

The following repair options are available when servicing Air Express control units:

1. Defective Components – replacement parts may be ordered by specifying the part number as shown in the parts lists.
2. Control unit repairs - If the control unit becomes inoperative and the cause cannot be determined, the complete control unit may be returned to the factory for servicing at the purchaser's expense (see Return Authorization).

#### 3.3 Return Authorization

Please contact your local dealer.

### 4. Specifications

#### Physical

Dimensions: 31 cm x 23 cm x 15 cm

Weight: 3.2 kg

Operating Temperature Range: 16°C to 32°C

#### Storage and Shipping Conditions

Ambient Temperature Range: -29°C to 49°C

Relative Humidity 10% to 100%  
Non-condensing

#### Electrical

Power: 230 VAC

Frequency: 50 Hz

Current: 0.1A

Fuse: 1.0 A



Type BF Equipment



Attention, Consult Accompanying Documents

**IPX0**

Protection Against Harmful Ingress of Liquids Ordinary Protection

## 5. Control Panel Features



*Figure 1 - Front Panel C1000DF*



### 5.1 Comfort Control Dial

Dial has a built in stop, rotation is limited to approximately 320° (From "MIN" to "MAX" Settings)

### 5.2 Alarm Silence Switch (Lighted)

Will activate or deactivate all audible and visual alarms. When switch is in the lighted position, all alarms will be active.

### 5.3 Mode Select Switch (Lighted)

In the  position the control unit will be in Alternating Pressure Mode. In the  position the control unit functions in Float/Static Mode.

### 5.4 Power On Light

AC Power is present and the control unit is turned on.

### 5.5 Low Pressure Warning Light

Indicator is on at startup until the attached mattress reaches minimum operating pressure, and when system is under minimum system pressure.

## 6. Rear & Side Panel Features

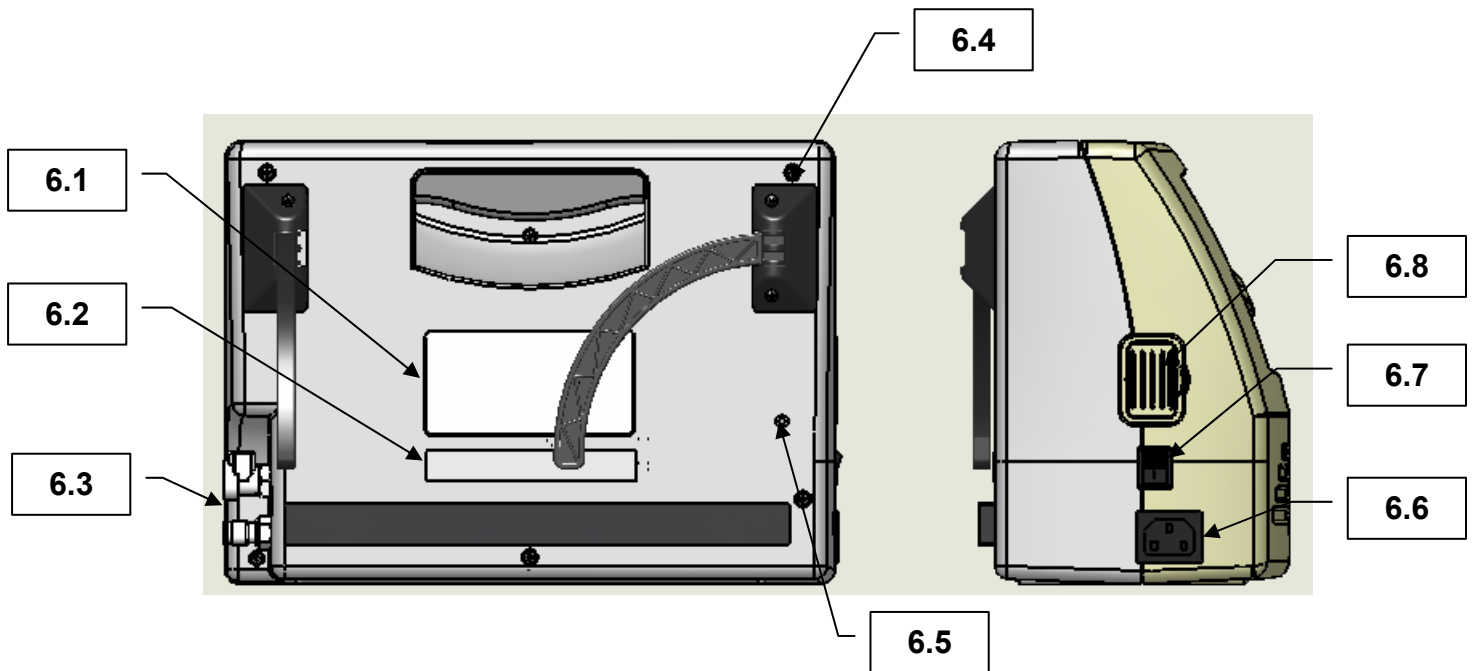

Figure 2 - Rear Panel Features

### 6.1. Identification Plate

### 6.2. Bar Code Label

This barcode label must not be removed from the unit. The model and serial number information is needed to arrange for returns to the factory.

### 6.3. Connectors

Male and female connectors are compatible with the couplings from the M280 overlay, and M1000 mattress.

### 6.4. Hooks

Hooks are to be used to attach the control unit to the foot board of the bed.

### 6.5. Ground access point

This point allows access for current leakage/ground resistance measurements.

### 6.6. Power Entry Module

Hospital grade power cord is connected here.

### 6.7. Power On/Off Switch

Turns the control unit on and off

### 6.8. Filter access point

Allows qualified medical service personnel to replace the air filter

## **7. Cleaning**

### **7.1. Control Unit**

To clean, moisten a clean cloth with mild soap and water. Wipe down the control unit exterior surfaces and power cord. Then wipe dry with a clean dry cloth. **Do not autoclave or submerge control unit.**

### **7.2. Mattress / Overlay**

Outside surfaces of mattress / overlay may be cleaned with a damp cloth and mild detergent. Then wipe down the mattress with a clean, dry cloth to remove any excess disinfectant.

Top sheets of mattress / overlay may also be laundered between patient uses or as required to maintain good patient hygiene. Fill the washing machine with warm water (70 - 194°F or 21 - 90°C). Add one cup of laundry detergent. Place no more than four top sheets in a single extra large load capacity washing machine. When wash cycle is complete, remove promptly from machine and ensure all excess water is drained from load. Place dryer on LOWEST heat setting, or AIR FLUFF if available until dry. Verify top sheet is completely dry before placing under patient.

If individual air cells of mattress become soiled, clean and disinfect as described above or simply replace air cell with a clean replacement. Single air cell replacement can be successfully achieved with patient remaining on the mattress.

## **8. Maintenance and Function Testing**

The following maintenance and test procedure should be performed by a qualified technician familiar with testing and maintaining medical products.

Allow unit to warm up for 1 hour prior to performing the following tests.

To insure proper testing results follow these procedures carefully, paying close attention to setups and required test equipment. Failure to follow the procedures can lead to inaccurate or misleading results.

Document the testing results using the checklist at the end of this section. Keep a copy of the test results for your records.

Testing of the Air Express should be performed annually or as prescribed by your facilities maintenance program.

Equipment requirements:

2 x 0-100mmHg pressure gauges	P/N: 10392
Test fixture hoses	P/N: 10140
Male Connector	P/N: 10329
Female Connector	P/N: 10330
Mattress Pressure test fixture	P/N: 11668000
Inflator/Deflator	P/N: 78386001
Flow meter with connector	P/N: 77484000
Electrical safety analyzer	-----
Locking Adhesive	-----

**8.1 Physical Inspection** (Record results on the Function Test Check Sheet)

Check the control unit for cracks or breaks in the housing. Rotate the comfort control dial clock-wise and counter-clockwise to verify that it stops at the minimum and maximum pressure settings and that it is on tight. Check the power cord connector for cracks/breaks. Check the on/off switch for proper operation. Verify that the bed hooks are in place and tight. Check the power cord for breaks and the blades on the plug for looseness. Replace or repair any irregularities found during physical inspection. Open filter access point, and check filter. If filter is contaminated, install replacement.

**8.2 Pressure Test** (Record results on the Function Test Check Sheet)

- 8.2.1 Connect the control unit as shown in FIGURE 3.
- 8.2.2 Turn power on/off and alarm switch on.
- 8.2.3 Adjust comfort control dial fully clockwise (MAXIMUM) setting, set mode select switch to the alternating pressure (A/P) mode and allow the unit to run for 1 hour.
- 8.2.4 Take initial pressure reading. One of the gauges should read greater than 25 mmHg and the other pressure gauge should read between 0-5 mmHg. If these readings cannot be obtained at the fully clockwise position the pump will need to be calibrated (See Calibration Procedure). If calibration process can not achieve correct pressures, the unit will need to be investigated and repaired before proceeding.
- 8.2.5 Adjust comfort control dial fully counter-clockwise (MINIMUM) setting, set mode select switch to the alternating pressure (A/P) mode.
- 8.2.6 Take pressure reading. One of the pressure gauges should read 15 to 18 mmHg and the other pressure gauge should read 0-5 mmHg. If these readings cannot be obtained at the fully counter-clockwise position the pump will need to be calibrated (See Calibration Procedure). If calibration process can not achieve correct pressures, the unit will need to be investigated and repaired before proceeding.
- 8.2.7 Allow unit to cycle at least three complete cycles (monitor pressure changes to verify A/P function) before taking the next readings.
- 8.2.8 During the cycling of the unit the pressure gauges should alternate between high and low pressure.
- 8.2.9 Verify that the unit continues to cycle for several minutes.
- 8.2.10 With the power on/off switch on and the unit running, disconnect the power cord. The unit should produce an audible and a visible alarm. Note: The 'Power on light' should be off.
- 8.2.11 Reconnect the power cord.

NOTE: The following step must be completed after the unit has been running for 1 hour. The low pressure alarm will only sound after the control unit has been turned on and running for approximately 50 minutes. (Example: during start-up mattress inflation)

- 8.2.12 Disconnect pressure gauges from both ports, verify that the low pressure indicator (audible, and visual) is on.

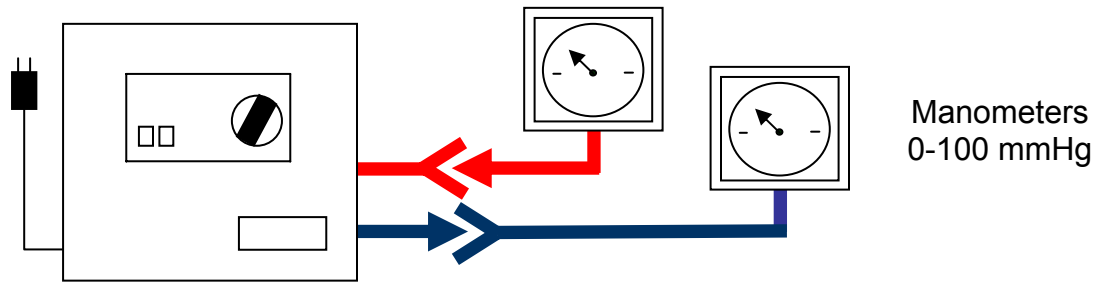

FIGURE 3

**8.3 Flow Test** (Record results on the Function Test Check Sheet)

- 8.3.1 Connect control unit to the flow meter as shown in FIGURE 4. Fully open flow meter (flow meter control knob turned counter-clockwise)
- 8.3.2 Turn on control unit, set mode select switch to the alternating pressure mode and adjust comfort control dial fully clockwise (MAXIMUM setting). The flow will fluctuate during alternation, Record the highest flow rate in a 12 minute period. Flow must exceed 5 LPM.

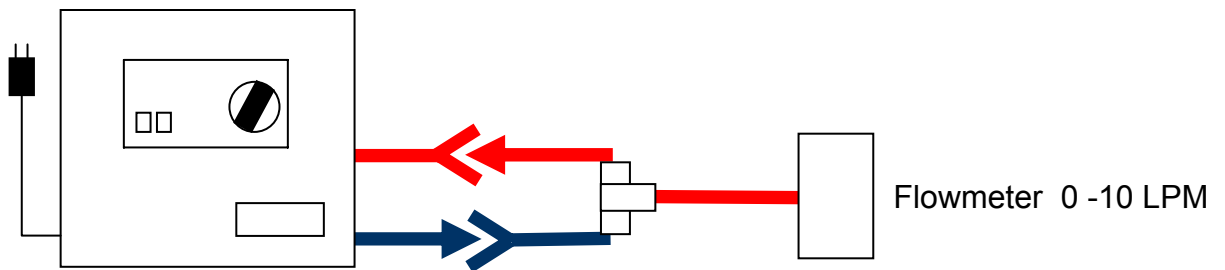
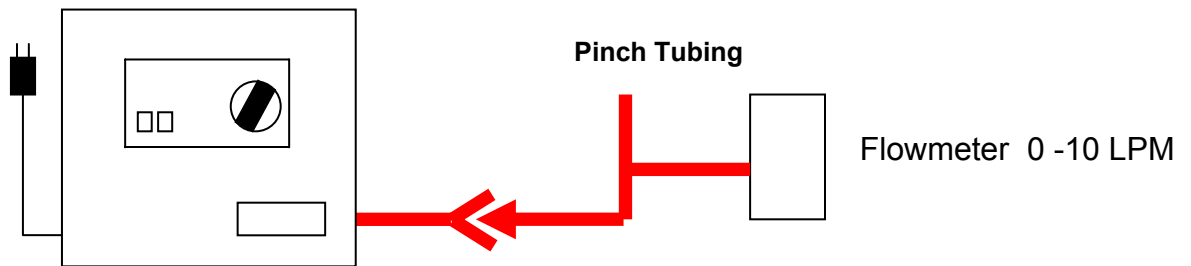

FIGURE 4

- 8.3.3 Set mode select switch to the float/static mode. Connect control unit to the flow meter as shown in FIGURE 5 (flow meter connected to top port). Wait a minimum of 6 minutes. Record the flow rate. Flow must exceed 2 LPM. Un-used tubing connection is to be plugged.





**FIGURE 5**

8.3.4 Repeat step 8.3.3 with flow meter connected to bottom port. Record the flow rate. Flow must exceed 2 LPM. Un-used tubing connection is to be plugged.

**8.4 Electrical safety inspection** (Record results on Function Test Check Sheet )

8.4.1 Connect the unit to an electrical safety analyzer. Using the analyzer manufacturer's instructions verify that the unit does not exceed 100  $\mu$ A (at 230 Volt) of current leakage in any combination of settings. Verify the ground connection does not exceed 0.5 ohms of resistance.

## 9. Function Test Check Sheet

Serial Number: \_\_\_\_\_

### Test Procedure Results

(See maintenance and function test section of manual for details)

Physical inspection OK?            Yes / No  
Filter check?                        Yes / No

### Testing (230Volt / 50 Hz)

- |                                                 |             |
|-------------------------------------------------|-------------|
| 1. High pressure reading observed.              | _____ mmHg  |
| 2. Low pressure reading observed.               | _____ mmHg  |
| 3. A/P Function test                            | Pass / Fail |
| 4. Pressure on both gauges?                     | Pass / Fail |
| 5. Power fail Indicator. (Audible and visual)?  | Pass / Fail |
| 6. Low pressure indicator (Audible and visual)? | Pass / Fail |
| 7. Flow test - A/P Mode                         | Pass / Fail |
| 8. Flow test – Static/Float Mode                | Pass / Fail |

### Electrical safety inspection results.

- |                                                 |             |
|-------------------------------------------------|-------------|
| 1. Max current leakage reading _____ $\mu$ amps |             |
| 2. Ground resistance less than 0.5 ohms         | Pass / Fail |

Tested by \_\_\_\_\_ Date \_\_\_\_\_

*If the unit passes all the steps described in the physical inspection, testing and electrical safety inspection sections above it should be considered ready for use. Any unit that does not pass all the requirements above should be serviced to correct the problem before being returned for use.*

## 10. Calibration Procedure (230Volt, 50 Hertz)

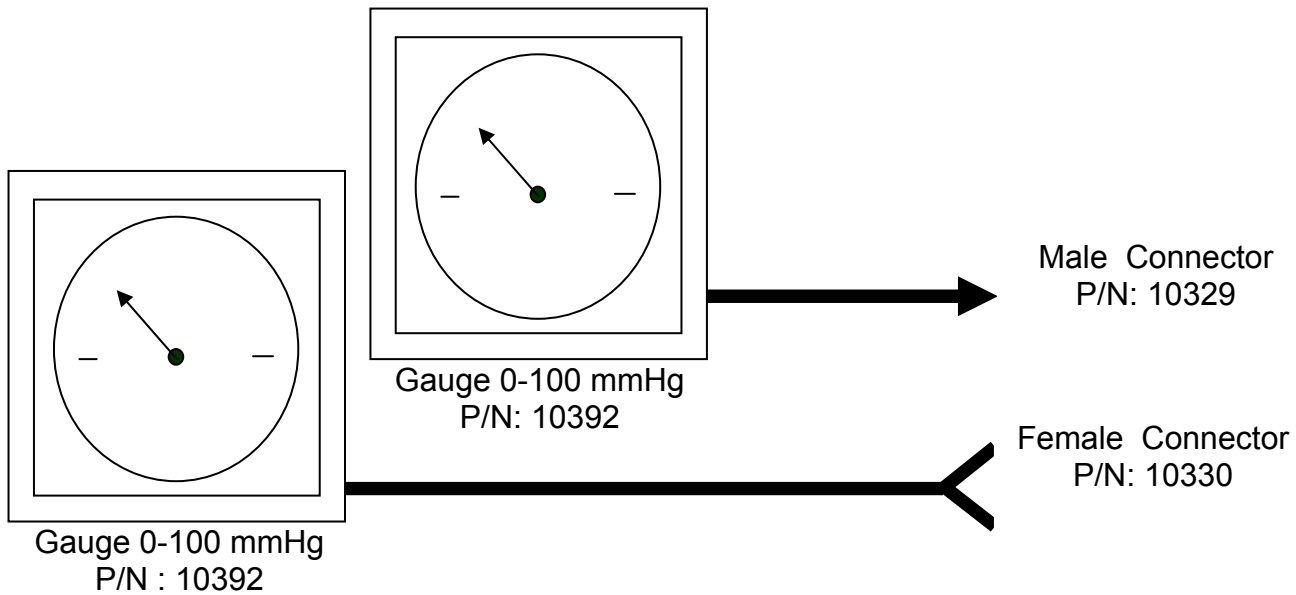

### Procedure:

**NOTE: Control unit must be set to the static/float mode and turned on for 1 hour prior to calibration.**

1. Grasp the comfort control dial and, remove by pulling away from the front panel of the control unit.
2. Open the control unit by removing the six (6) screws located on the back of the unit.

**RISK OF SHOCK - Use caution, the unit is plugged in and running!**

3. Connect gages to control unit as shown in FIGURE 3 (Page 6).
4. Adjust the Internal Pressure Relief Valve (located inside the control unit) by "pinching off" the tubing leading to the External Pressure Relief Valve and rotating the stem of the Internal Pressure Relief Valve until the pressure reads  $40 \pm 5$  mmHg on one of the gauges.
5. Once the Internal Pressure Relief Valve is calibrated, apply locking adhesive to internal pressure relief valve threads at the mating surface with the plastic body.
6. Now adjust the external pressure relief valve (no tubing is to be "pinched off" during this step) until the pressure reads 15 - 18mmHg on one of the gauges.
7. Reinstall the control dial onto the External Pressure Relief Valve with the indicaton the dial positoned at the minimum position. The control dial must be fully seated onto the external pressure relief valve.
8. Verify that the pressure of the control unit at the 'MIN' setting is between 15 and 18 mmHg.
9. Turn the control dial to its maximum position. Verify that the pressure is greater than 25 mmHg
10. Close unit, and once again verify the control units pressures at the 'MIN' and 'MAX' settings.

# 11. Troubleshooting

## Loss of Power

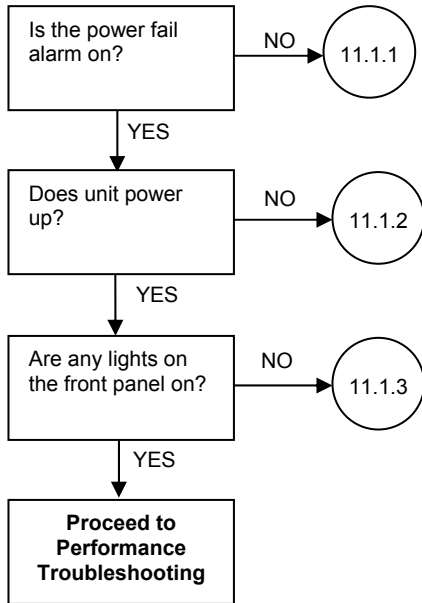

### 11.1 Loss of Power:

Symptoms: Power on light is off, Audible alarm sounding, visual alarm blinking, compressor not running.

11.1.1 Check the power at service level. This can be checked by plugging another appliance into the same power source, or detecting the voltage with a meter. Check the power cord is secured in the socket at the service, and at the power entry module.

11.1.2 Check power cord for cuts, and verify electrical continuity of the power cord (*This can be done by checking the resistance of each conductor across the power cord*).

11.1.3 Check the fuses: Unplug control unit before opening the enclosure. Check continuity of the fuses. This check is performed by checking resistance on the blue and brown wires (Containing the fuses) that connect to the power entry module. If fuses have failed review electrical connection for a short.

### 11.2 Loss of performance

Symptoms: Failure to meet functional test requirements, loss of pressure alarm on after mattress is filled.

11.2.1 Check for kinked or split tubing in the control unit, or between the control unit and the mattress. Check the mattress for disconnected cells, or leaks in the cells.

11.2.2 If the MAX pressure cannot be corrected by the calibration procedure, check the control unit for leaks. Check the connectors for cracks, or missing o-ring. Check pump for operation, you will feel vibration on the pump when it is running.

11.2.3 If the MIN pressure cannot be corrected by the calibration procedure, check the control unit for leaks. Check the connectors for cracks, or missing o-ring. Check pump for operation, you will feel vibration on the pump when it is running.

11.2.4 If the flow is not correct at the MAX pressure setting, contact the dealer for assistance.

## Performance Problems

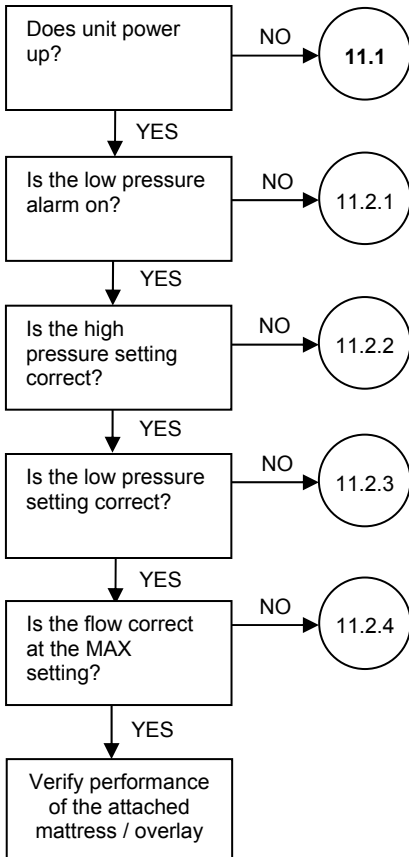

**12. Parts List**

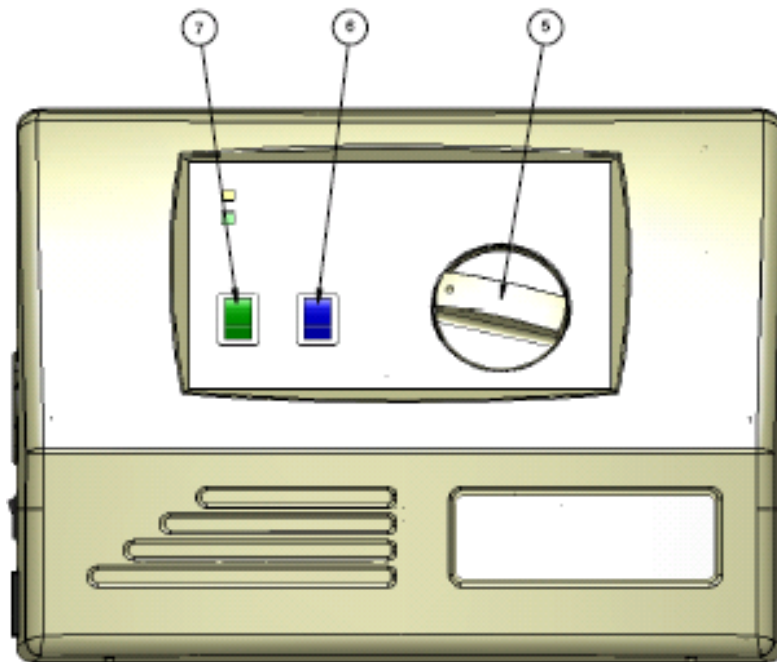

1	100044000	SWITCH, MODE SELECT	7
1	100045000	SWITCH, ALARM SHUTOFF	6
1	100056000	KNOB, PRESSURE ADJUST	5
1	100047000	FILTER, DUST	4
1	100048000	DOOR, FILTER	3
1	100043000	SWITCH, ASSEMBLY, ON/OFF	2
1	100049000	MODULE, POWER ENTRY	1
QTY	GAYMAR P/N	DESCRIPTION	ITEM

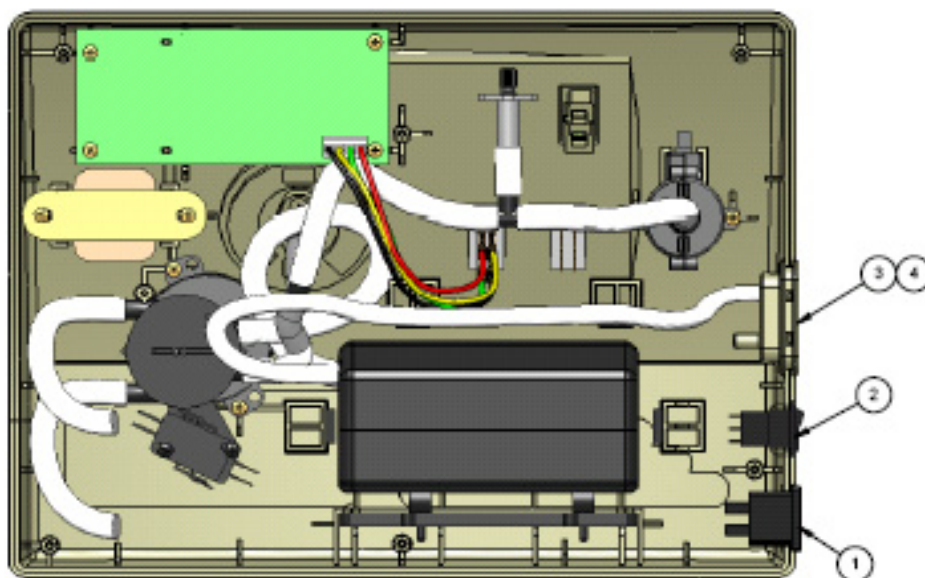

### 13. Electrical Schematic

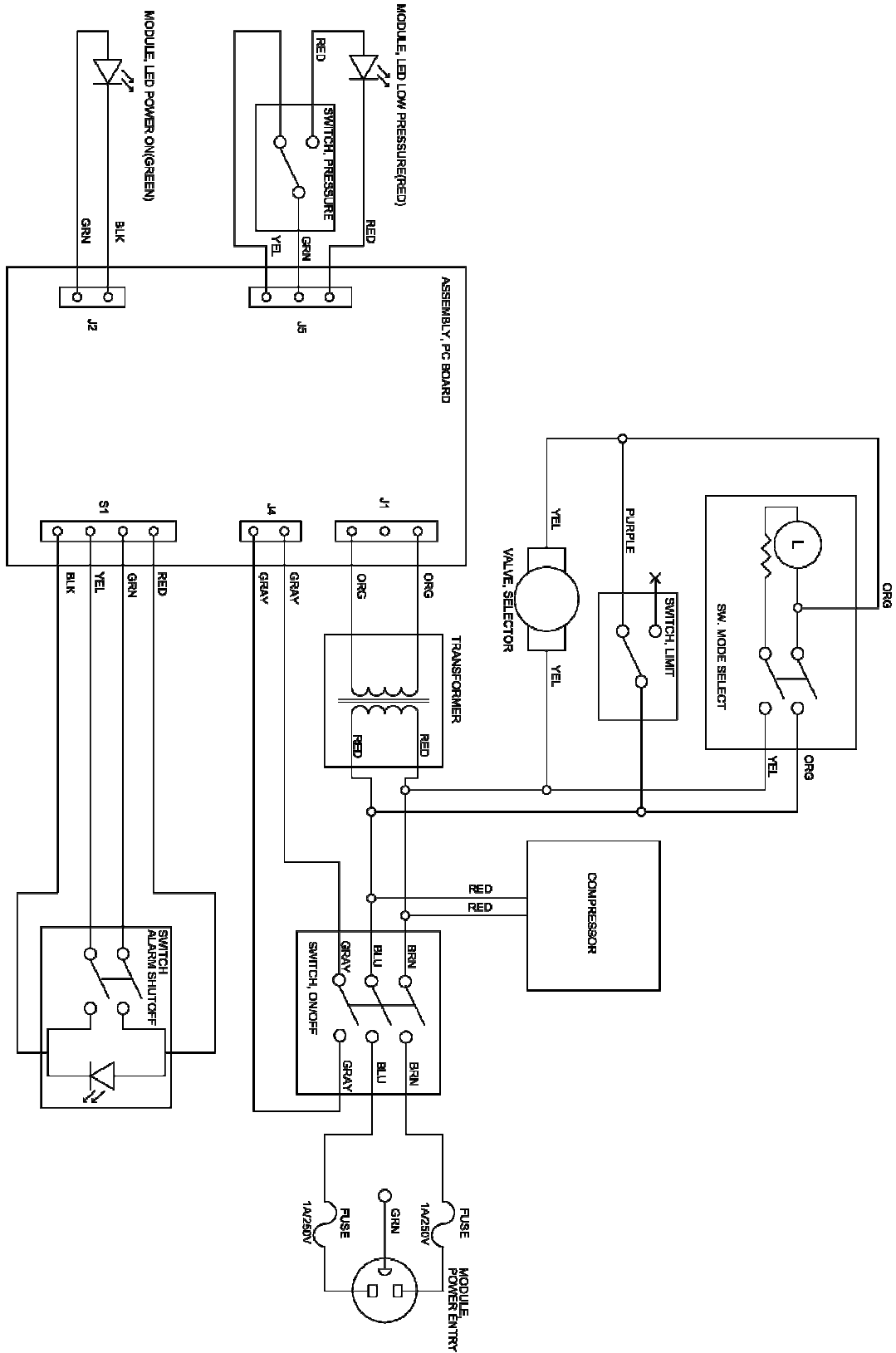

# 14. Pneumatic Schematic

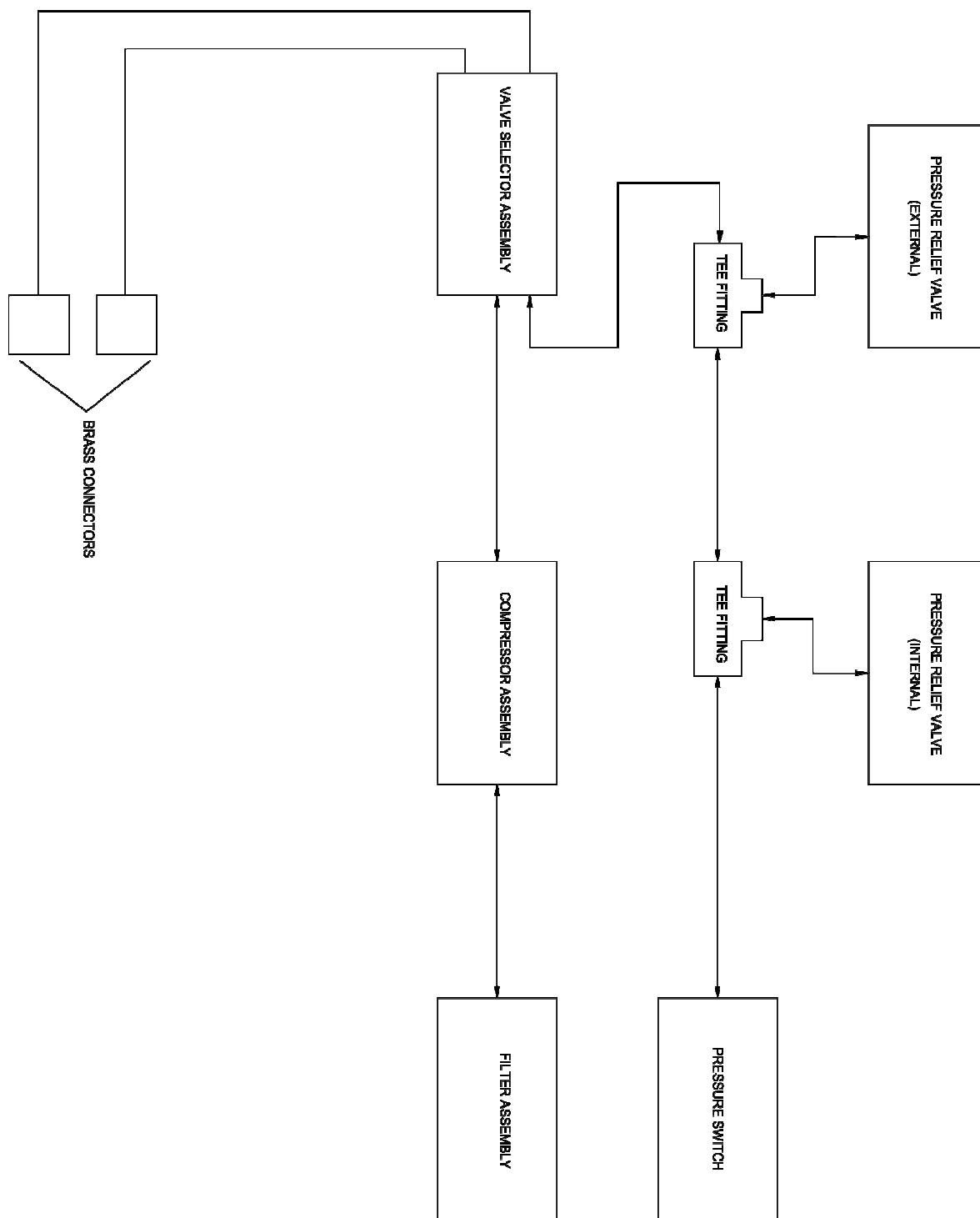



10 Centre Drive  
Orchard Park, NY  
14127-2295

USA Only

Phone:

(800) 828-7341

(716) 662-2551

Fax:

(800) 993-7890

(716) 662-0748

Outside USA

Phone:

(716) 662-8636

Fax:

(716) 662-0730

**Authorized EC Representative**

INVATECH GmbH & Co. KG

Königsreihe 22

D-22041 Hamburg, Germany